

Todi Biennale

SGUARDO -- Jiang Qinxiao

CONTESTO AMBIENTALE



Il mio lavoro è composto da **10 tavolini in plastica di altezze diverse**, i quali sono ricoperti da “tovaglie” in fibra sintetica con dei ricami bianchi e neri.

La scelta di questi materiali è voluta per via dell’allestimento dell’installazione in esterno.

Questi ricami sono stati ispirati dalle mappe geografiche di alcune zone del mondo in cui esistono possibilità di comunicazione, o di conflitto. Ho diviso e riorganizzato diverse parti delle mappe per creare un'immagine armoniosa, rappresentata dagli occhi. **Gli occhi** sono un simbolo dello sguardo e del modo in cui percepiamo il mondo.

Ho cucito questi occhi utilizzando **fili di nylon bianchi e neri**, i quali fissano il cielo di Todi, occhi provenienti dall'oriente che osservano il mondo occidentale.

Le linee bianche e nere che ho utilizzato simboleggiano culture diverse, indipendenti ma collegate tra loro. Nella cultura cinese, questi colori rappresentano l'equilibrio e l'armonia. Nel mio lavoro, cerco di esprimere una **sinergia tra culture differenti**.

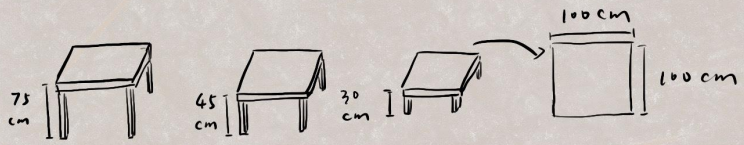

alture diverse

utilizzando
fili di nylon
tavolini di
plastica

ricamo
degli occhi

BOZZETTO

Sguardo
Jiang wixiao

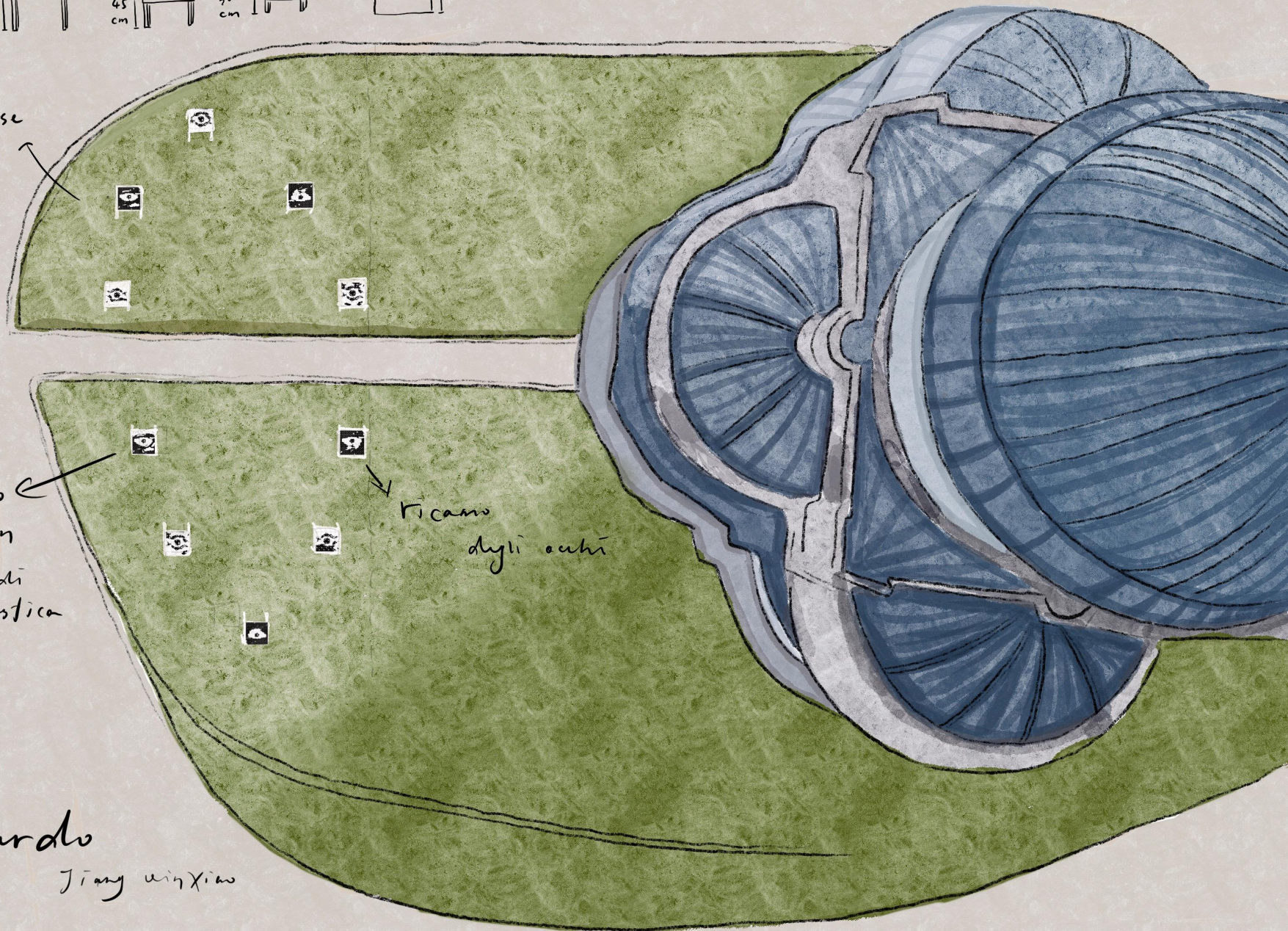

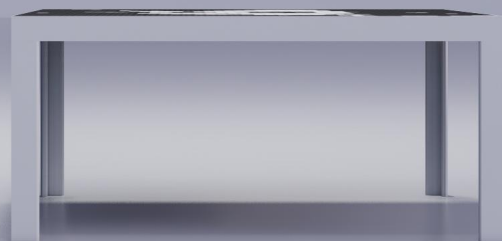

3D modelli

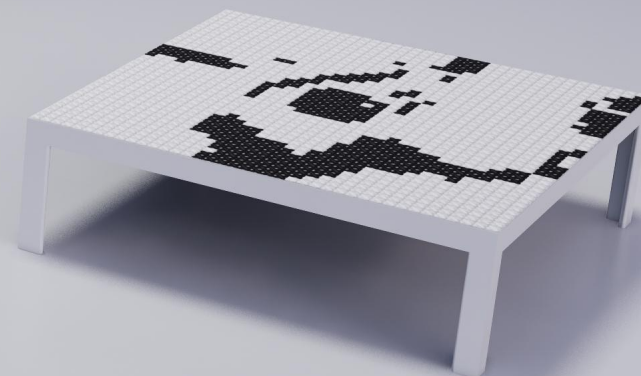
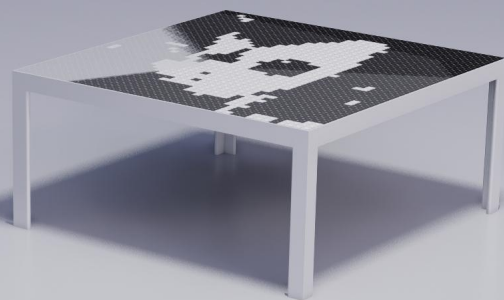
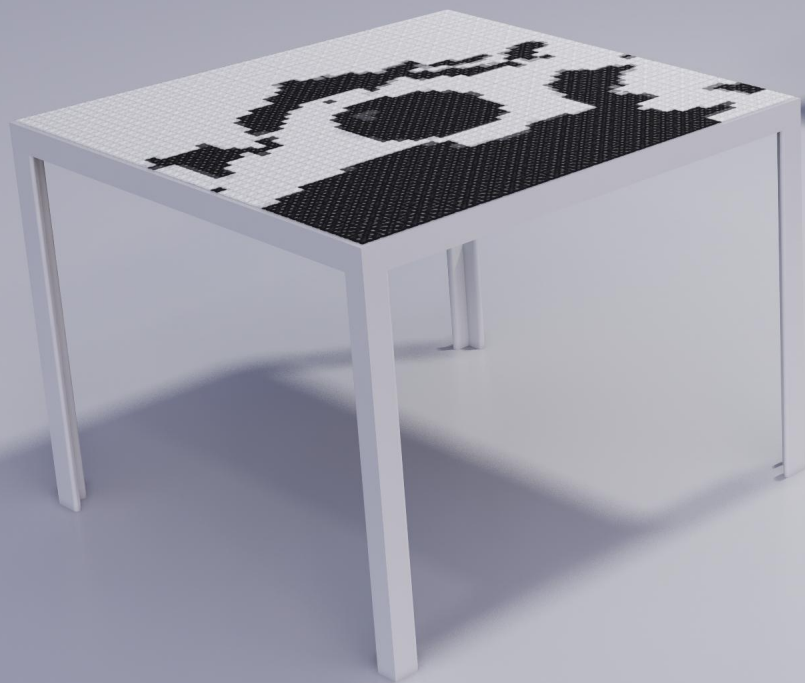

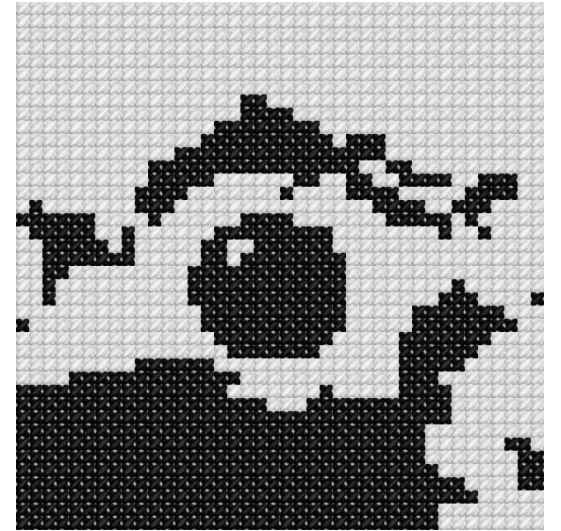

La cartina geografica



Ricamo

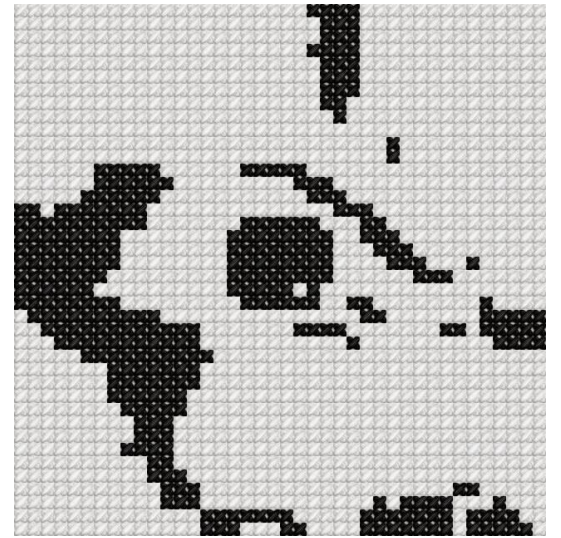
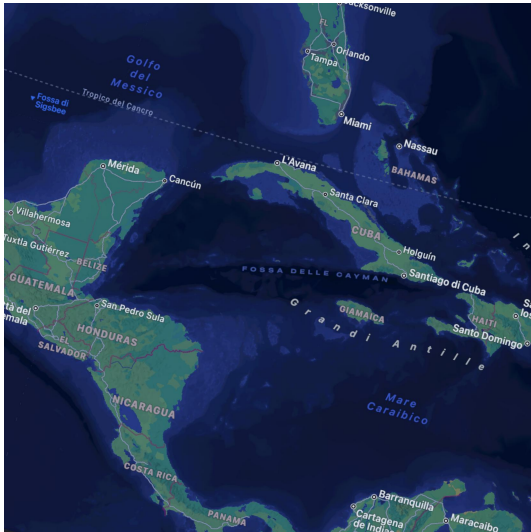

DIMENSIONI

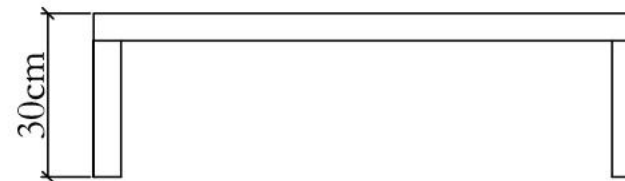
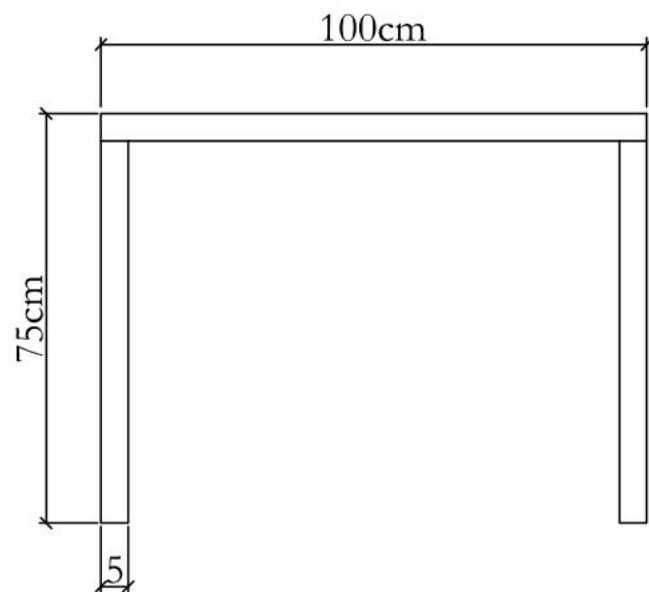
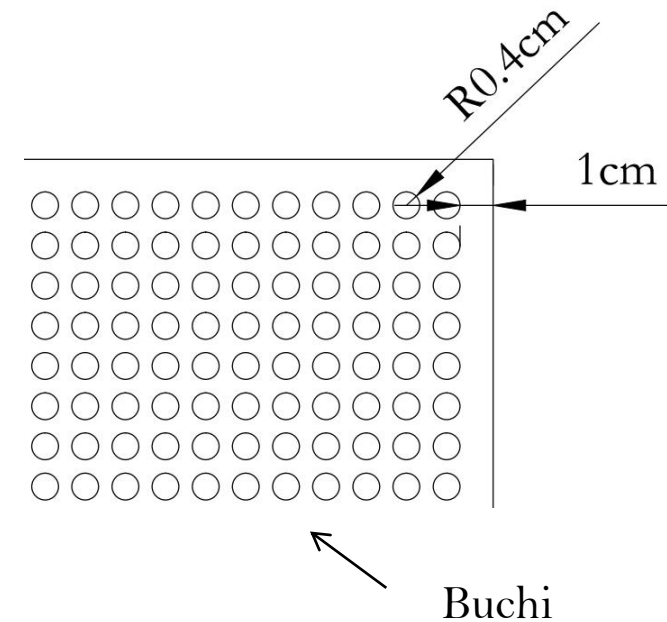
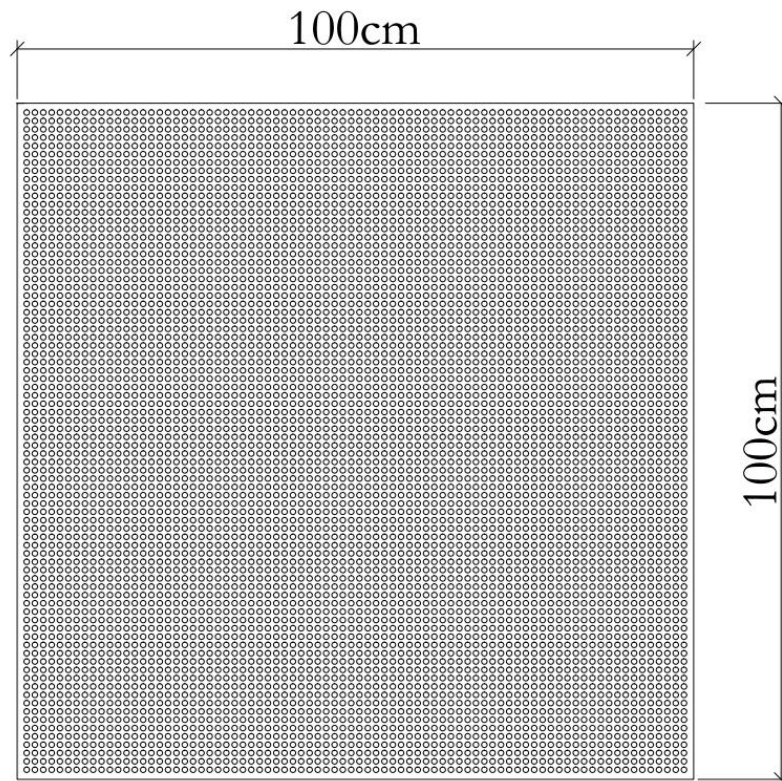

Tavolini di altezze diverse